

UNIT DESCRIPTION  
 24 in. CABINET

ASSEMBLED DIMENSIONS (H X W X D)

74-<sup>5</sup>/<sub>16</sub>in.H x 23-11/16 in.W x 15-3/8 in.D  
 188.7 cmH x 60.2 cmW x 39.1 cmD

FINISH: (401) WHITE AQUASEAL  
 (403) ONTARIO WHITE  
 WEIGHT: 95 LBS (43.1 KG)

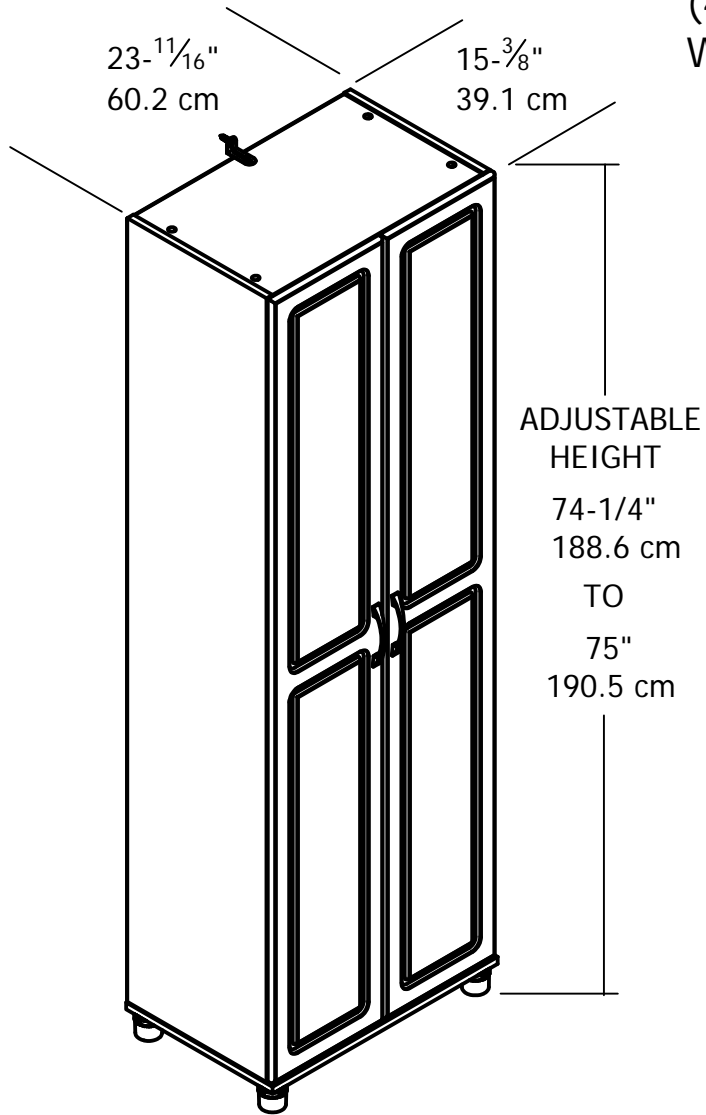

ADJUSTABLE FEET:  
 2-<sup>1</sup>/<sub>4</sub>" TO 3"

